

# Optical Systems for Image Processing and Metrology





# Optical Systems for Image Processing and Metrology

## CCD Camera Lenses

Basics	5
Lens Selection Formulae	6
Working Distance and Magnification	7
Compact Lenses for 1/3"	
CCD Cameras	8
Measuring Lenses MeVis-C / Cm	10
Telecentric Lenses TL	15
Macro CCD Lenses	16
Measuring Lenses for Large Imaging Sensors	21

## Mechanical Accessories

Mechanical Adaptions	26
Modular Focus	27
Smart Focus	28
Focus Adapter System	29
Fax Form	30
Specification Sheet Optical Systems	31



**No compromises. LINOS provides consistently outstanding design and production for all your optical requirements.**

To keep up with the pace of development in the field of industrial image processing, the optics used must always be a step ahead. Flexibility, robustness and precision must meet the highest standards and yet not be the decisive cost factor.

LINOS systems enable 100% quality control in manufacturing. Our long-standing experience with opto-mechatronic systems and our extensive technology transfer across a wide variety of industries and research institutions enable us to continuously optimise our systems.

On this basis, we are able to provide a wide range of high-quality standard components for any application, which allows highly sophisticated special solutions to be implemented at any time without the high cost involved in internal development.

But many years of successful research and development work have provided us with an even greater insight of the field: As a result, we can also make a valuable contribution to planning the application solution beyond systems integration.

When it comes to innovation, even the smallest element is ultimately indispensable. For this reason, every single component and production series is carefully registered and archived. This allows us to guarantee both long-term availability and fast global access.

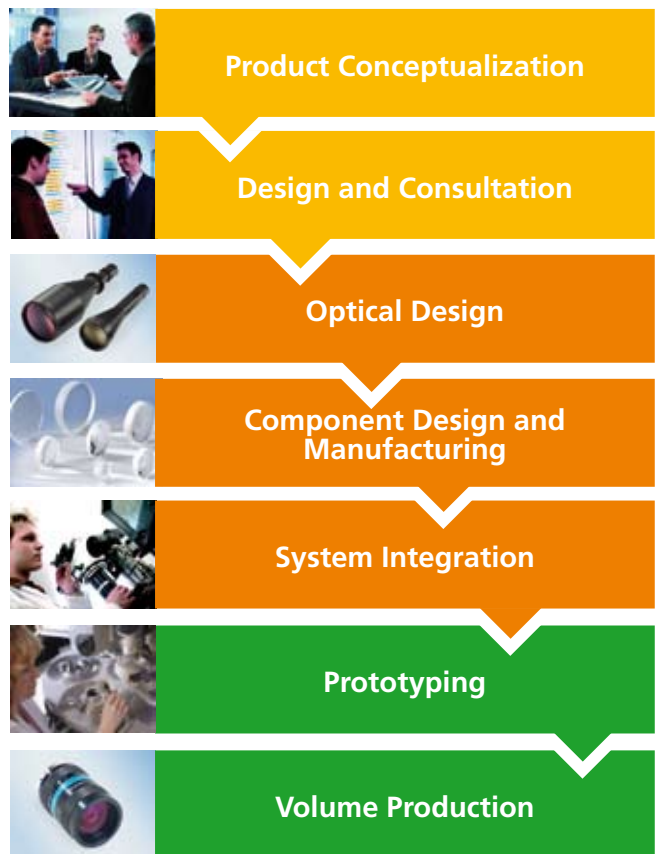

# CCD-Camera Lenses

## Basics

Besides the camera chip, optics are the most important components in relation to resolution and quality in image processing. LINOS lenses feature excellent imaging capabilities throughout the entire image field captured or photographed. The mechanical construction of LINOS lenses is rugged, making them ideal for use in industry.

### Important Basic Terms

#### Contrast

Also called "modulation". The ratio of the differences to the sum of the maximum and minimum illuminance of two self-illuminating or illuminated surface points. Put in more accurate terms, the ratio of the difference to the sum of two intensities.

#### Depth of field

The axial plus or minus distance from an object space, which is reproduced as an image without any perceptible loss in sharpness. The receiver-dependent circle of confusion permitted in the image plane is decisive for the depth of field.

#### F-number

While imaging from infinity, the ratio of the diameter of the entrance pupil EP to the focal length of an optical imaging system  $f'$ . Put in more accurate terms,  $k = 0.5 / NA$  (see also "Numerical aperture").

#### Image height (max. sensor sizes)

1/4" CCD	$2u' = 4 \text{ mm}$
1/3" CCD	$2u' = 6 \text{ mm}$
1/2" CCD	$2u' = 8 \text{ mm}$
2/3" CCD	$2u' = 11 \text{ mm}$
1" CCD	$2u' = 16 \text{ mm}$

#### Minimum object distance (MOD)

The smallest possible difference from the object is given for each lens.

#### Modulation transfer function (MTF)

Quantitative description of the image forming power of an imaging system. To determine MTF, increasingly fine lines (spatial frequency in line pairs per mm) of known contrast are imaged by the optical system and the image modulation is measured in the image plane. The ratio of the image modulation to the object modulation as a function of the spatial frequency yields MTF.

#### Numerical aperture N(A)

The numerical aperture NA is a characteristic value for the widest ray bundle capable of entering a lens. It is strictly indicated as a numerical value:  $NA = n \times \sin \sigma$  ( $n$  = index of refraction,  $\sigma$  = half angle ray bundle). NA (see also "Resolution") defines the maximum resolution (limited by light propagation) of an optical system.

#### Resolution

The maximum resolution of an image processing system is ultimately determined by the pixel dimensions of the CCD chip. In order to resolve a pair of light and dark lines, two pixels (see also "MTF") are needed. Resolution is limited by light propagation. Because of the wave nature of light, even an ideal lens does not reproduce the image of a point as a sharp dot, rather as a diffraction disc (Airy disc:  $\varnothing \text{ Airy} = 2.44 \times \lambda \times k$  where  $\lambda$  = wavelength and  $k$  = f-number) with concentric light and dark rings; according to Rayleigh, this is the limit of resolution.

#### Stop

Limits the ray bundles between the object and image by mechanical reasons during optical imaging. The diaphragm or aperture affects the brightness of an image. In addition, the size and position of the diaphragm or aperture determine the angle, resolution and depth of field.

#### Telecentric system

An optical system where the entrance and/or exit pupil is imaged to infinity caused by locating the aperture stop at the front or back focal point of the system. Because of this, the principal rays are parallel to the optical axis in the image and/or object space. Thus, it yields a special form of perspective: telecentric (as opposed to the natural entocentric perspective). Through telecentric perspective, objects of the same lateral distance on both sides appear to be equal in size at various distances within specific limits (telecentric range) in an image.

# Lens Selection Formulae

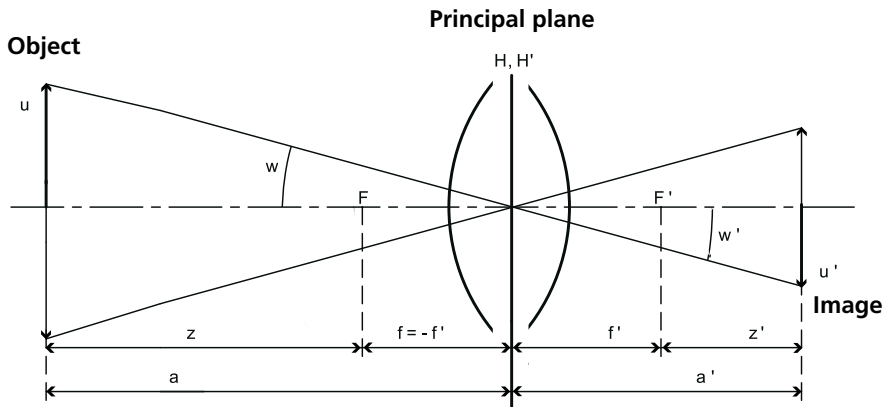

- $F, F'$  Focal points
- $H, H'$  Principal points
- $a$  Object distance
- $a'$  Image distance
- $f, f'$  Focal length
- $u$  Object height
- $u'$  Image height
- $w$  Object angle
- $w'$  Image angle
- $z$  Subject-F distance
- $z'$  Subject-F' distance

## Sign Conventions

The light path follows the direction from left to right. Paths measured in the

direction of light are positive and those in the opposite direction of light are negative. Paths perpendicular to the

optical axis are positive above the axis and negative below it (in this case, for example,  $u'$  is negative).

Magnification	$\beta' = \frac{u'}{u}$	Object height	$u = \left(\frac{a}{f'} - 1\right) \cdot u'$
Focal length	$f' = \frac{a}{1 + \frac{1}{\beta'}}$	Image height	$u' = \frac{1}{\frac{a}{f'} - 1} \cdot u$
F-number	$k = \frac{f'}{\varnothing_{EP}}$	Depth of field	$\Delta a = a_f - a_n$
Object angle	$w = \arctan \frac{u'}{f'}$	Near limit	$a_n = \frac{a \cdot f'^2}{f'^2 + \Delta u' \cdot k \cdot (a + f')}$
Object distance	$a = \left(\frac{1}{\beta'} + 1\right) \cdot f'$	Far limit	$a_f = \frac{a \cdot f'^2}{f'^2 - \Delta u' \cdot k \cdot (a + f')}$
Image distance	$a' = (1 + \beta') \cdot f'$	Circle of confusion of CCD sensors	$\Delta u' = 20 \text{ to } 30 \mu\text{m}$ .

The minimum object distances (MOD, see charts of lenses) are determined by the maximum possible focusing limits. For extreme close-up work (less than MOD), there are two major approaches to effectively reducing these limits:

### a) Inserting one or more extension tubes

The total length of extension tube(s) needed to yield magnification of an objective lens of a specific focal length is given by:

$$\text{Extension tube length} \quad z' = \beta' \cdot f'$$

### b) Inserting an auxiliary positive lens

The power in diopters of the auxiliary close-up lens needed for working at a specific object distance is:

$$\text{Close-up lens power} \quad D[\text{dpt}] = \frac{1}{a[\text{m}]}$$

# Working Distance and Magnification

The diagram below shows which particular free working distances from the front edge of a lens are yielded at various magnifications. It enables the best focal length to be

determined based on the practical requirements of each specific application. As LINOS offers a variety of different types of lenses in the stated focal

length range of 16 to 105 mm, there are several models to choose from for most nominal focal lengths in order to accommodate different quality requirements.

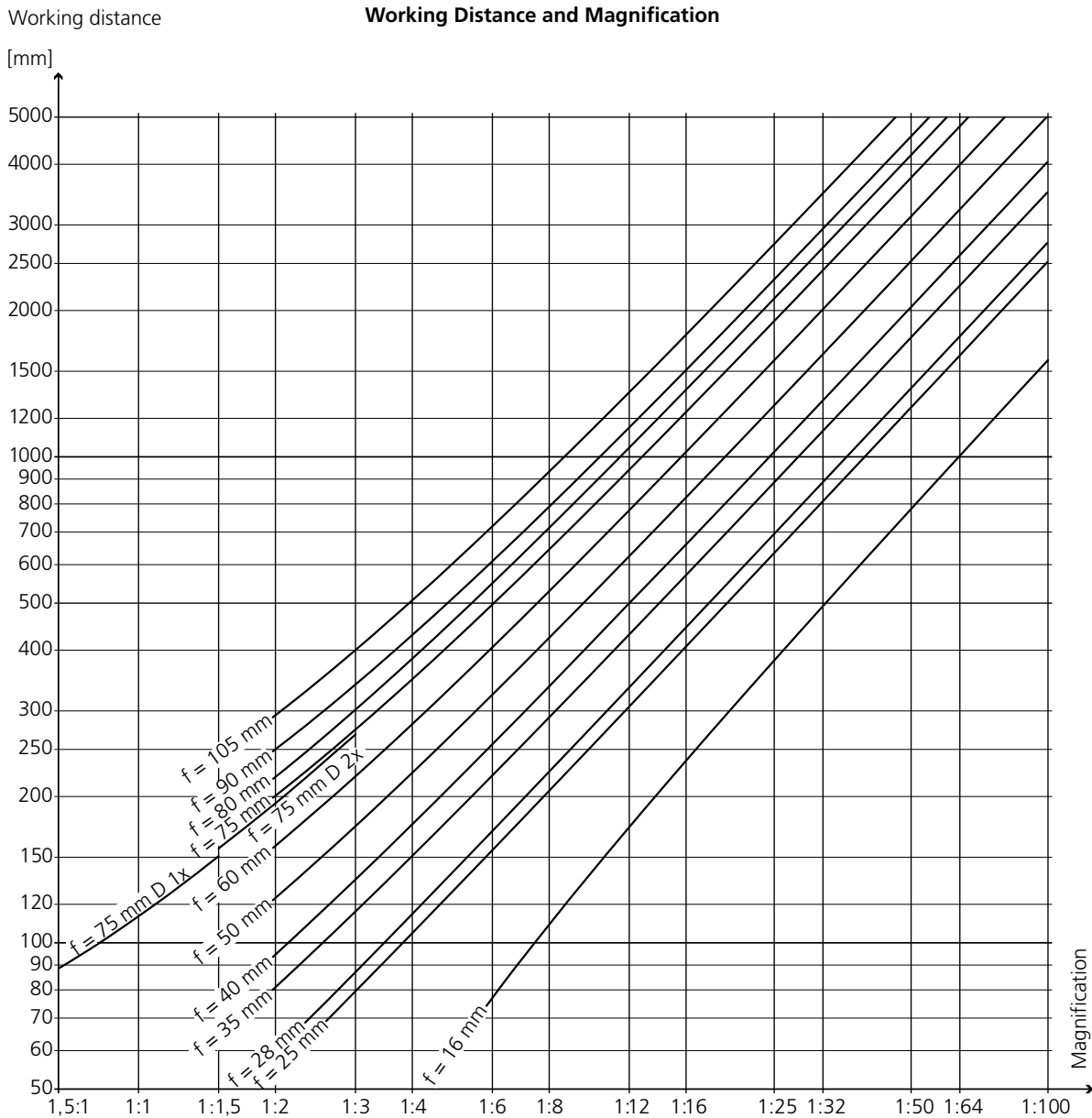

LINOS lenses are suitable for CCD applications with focal lengths ranging from 16 to 105 mm. We recommend

them for magnifications between 1: ∞ and approximately 1:2. The special Apo-Rodagon-D 1:4 / 75 mm has been

optimized for magnifications in the range of 1:1.

## Compact Lenses for 1/3" CCD Cameras With $\varnothing$ 12 mm for use in microcameras

Because of their extreme compactness, microcameras with 1/3" CCD are ideal for monitoring and testing applications in which the camera dimensions must be very small or the camera weight has to be very light.

- for the wavelength range from 400 to 700 nm
- broad focal length range from 3.8 up to 30 mm
- maximum reproduction of detail
- high contrast
- low distortion and uniform image field illumination (low vignetting)

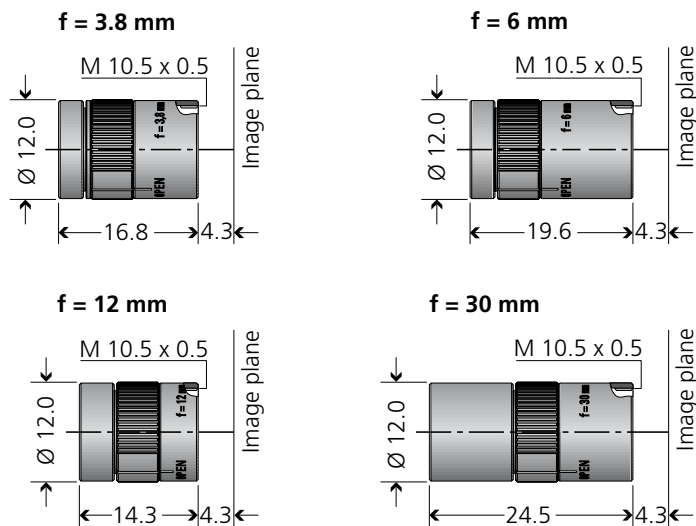

## Specifications

Lens designation	1/3" CCD Lens - 3.8	1/3" CCD Lens - 6	1/3" CCD Lens - 12	1/3" CCD Lens - 30
Aperture ratio	2	2	2	3.4
Focal length	3.8 mm	6 mm	12 mm	30 mm
Means of focus	iris diaphragm	iris diaphragm	iris diaphragm	iris diaphragm
Image angle horizontal x vertical	75° x 55°	47° x 34°	23° x 17°	9° x 7°
Image size width x height	4.8 mm x 3.6 mm	4.8 mm x 3.6 mm	4.8 mm x 3.6 mm	4.8 mm x 3.6 mm
Magnification range*	1: ∞ ... 1:10	1: ∞ ... 1:6	1: ∞ ... 1:5	1: ∞ ... 1:10
Distance range from the front edge of the mount	∞ ... 35 mm	∞ ... 35 mm	∞ ... 65 mm	∞ ... 330 mm
Video distortion	- 8 %	- 3 %	- 0.3 %	less than - 0.1 %
Rel. brightness in the image corner of the 1/3" CCD	63 % (open diaphragm)	77 % (open diaphragm)	62 % (open diaphragm)	70 % (open diaphragm)
Resolution in the center of the image with open diaphragm	1000 TV lines	1000 TV lines	1000 TV lines	1000 TV lines
Resolution in the image corner with open diaphragm	400 TV lines	450 TV lines	500 TV lines	1000 TV lines
Wavelength range	400 - 700 nm	400 - 700 nm	400 - 700 nm	400 - 700 nm
Part No.	263.004.001.020	263.006.001.020	263.0012.001.020	263.0030.001.020

\* Focusing is done using the threaded mount and locking collar.

## Measuring Lenses MeVis-C / Cm

- excellent resolution, uniform distribution of brightness over the entire image field and no distortion
- developed for the spectral range of 400 - 900 nm (VIS and NIR)
- C-mount adapter for CCD Cameras
- lockable focusing and diaphragm settings
- free of irritating color edging
- no color fringing when 3-chip cameras with beamsplitters are used
- maximum sensor size 2/3" for f=12 mm and 16 mm and 1" for f=25 mm, 35 mm and 50 mm
- with filter thread M 35.5 x 0.5
- optimized for a wide range of magnifications
- objects of different sizes are sharply reproduced between the minimum object distance (MOD) and infinity



**Measuring Lens MeVis-C**

Specifications	Measuring lens MeVis-C				
Focal length	12 mm	16 mm	25 mm	35 mm	50 mm
F-number	1.8	1.6	1.6	1.6	1.8
Max. sensor size	2/3"	2/3"	1"	1"	1"
MOD	0.03 m	0.15 m	0.26 m	0.37 m	0.67 m
Spectral range	400 - 900 nm	400 - 900 nm	400 - 900 nm	400 - 900 nm	400 - 900 nm
Camera threaded mount	C-Mount	C-Mount	C-Mount	C-Mount	C-Mount
Depth of thread	3.5 mm	3.5 mm	3.5 mm	3.5 mm	3.5 mm
Fokusing	manual, lockable	manual, lockable	manual, lockable	manual, lockable	manual, lockable
Iris diaphragm	manual, lockable	manual, lockable	manual, lockable	manual, lockable	manual, lockable
F-number range	1.8 ... 16	1.6 ... 16	1.6 ... 16	1.6 ... 16	1.8 ... 16
Filter thread	M 35.5 x 0.5	M 35.5 x 0.5	M 35.5 x 0.5	M 35.5 x 0.5	M 35.5 x 0.5
Length	63.9 mm	51.2 mm	44.1 mm	59.4 mm	67.5 mm
Diameter	42 mm	42 mm	42 mm	42 mm	42 mm
Weight	275 g	170 g	156 g	210 g	240 g
Part No.	266.0012.001.040	266.0016.001.040	266.0025.001.040	266.0035.001.040	266.0050.001.040

## Measuring Lens MeVis-C

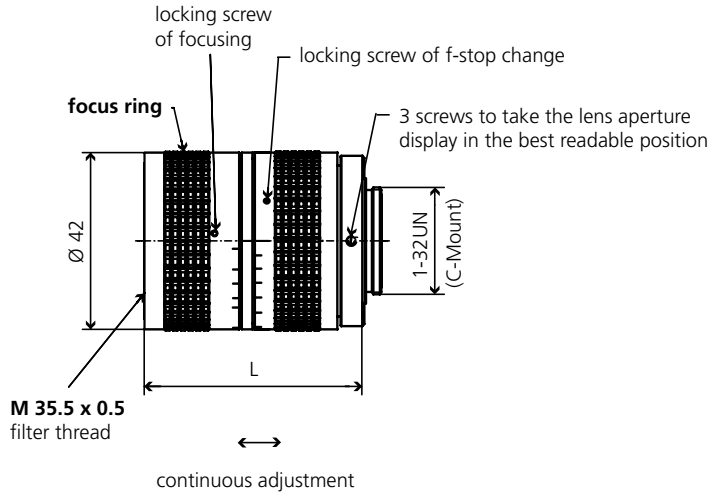

Focal length	Length L	Part No.
12 mm	63.9 mm	266.0012.001.040
16 mm	51.2 mm	266.0016.001.040
25 mm	44.1 mm	266.0025.001.040
35 mm	59.4 mm	266.0035.001.040
50 mm	67.5 mm	266.0050.001.040

## MTF of MeVis-C Lens f = 25 mm

MTF at ratio 20x f / 1.6

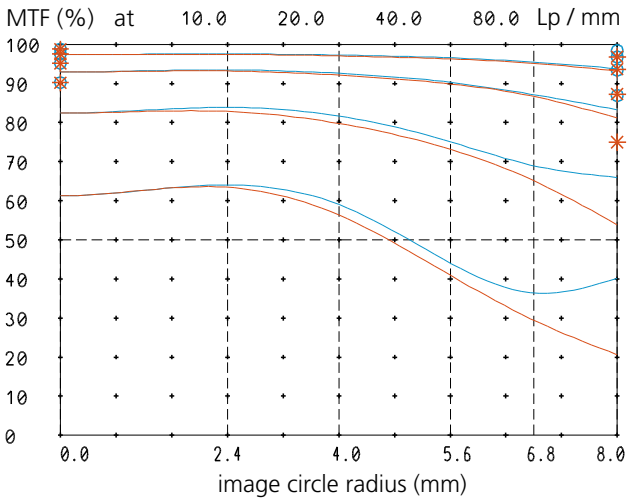

MTF at ratio 20x f / 2.8

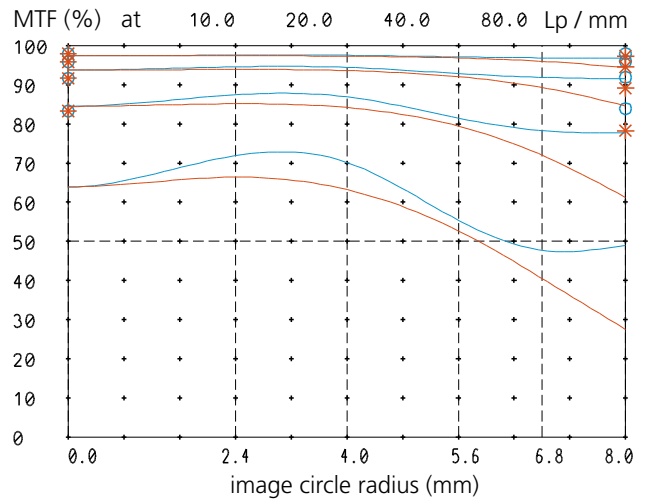

## The motorized version of the MeVis-C series

As image processing systems become increasingly integrated into production equipment, manufacturers are faced with growing requirements on the optical systems. Thanks to their outstanding optical properties, the proven MeVis-C lenses from LINOS meet the highest demands. Therefore, MeVis lenses are the No. 1 choice when it comes to industrial inspection and machine vision.

To meet the added requirements on high flexibility, LINOS expanded its product series with a motorized version. Motorization of the MeVis-Cm lenses enables automated adjustment of the focus and diaphragm, which is a tremendous advantage, for instance, for fixed equipment that is difficult to access. Encoders in the MeVis-Cm ensure precise and reproducible adjustment.

MeVis-Cm lenses are easy to integrate, for example, into industrial inspection equipment for production plants. The reason is that the lenses have a C-mount fitting for simple mechanical adaptation to CCD Cameras. Because of their rugged design, the motorized lenses are ideal for use under tough industrial conditions.

### Optical Properties of MeVis-C

- high imaging quality
- high resolution over the entire sensor area (also for 1-inch CCD sensors)
- no vignetting; which means there are no dark edges or corners surrounding the image
- minimum distortion
- no color shading
- free of interfering color fringing
- spectral range 450 – 900 nm
- available in focal lengths of 12, 16, 25, 35 and 50 mm

### Features of the MeVis-Cm Series

- motorized diaphragm and focus
- easy evaluation by potentiometers
- 5 V power supply
- user-configurable connections
- motors and potentiometers can be individually controlled
- easy to integrate into available equipment
- rugged and industry-compatible version

## Technical Drawings

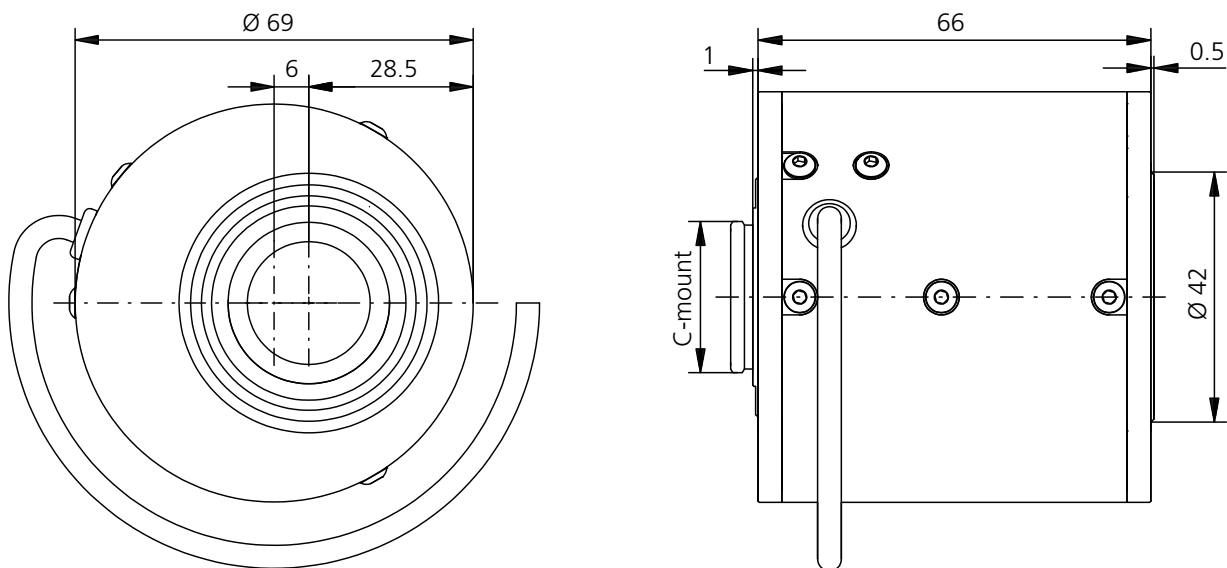

## Specifications

Parameter	Specifications	Remarks
Lenses	LINOS MeVis-Cm	-
Motorization	Focus and diaphragm	-
Focusing range	Continuous up to 1 m	or up to 2 m in the near range
Control	5 V DC, 300 mA	-
Connection	500-mm cable	Open cable ends
Motors	Faulhaber geared motors, type 1016M012G10/1K 256:1	Focus and diaphragm
Encoders	Farnell potentiometers, 10 kohm, type 32 82 569	Focus and diaphragm

Cable	Function	Color
1	1 Potentiometer Diaphragm	Brown
2	3 Potentiometer Diaphragm	White
3	2 Potentiometer Diaphragm	Green
4	2 Potentiometer Focus	Yellow
5	1 Potentiometer Focus	Gray
6	3 Potentiometer Focus	Pink
7	- Motor Focus -	Blue
8	+ Motor Focus	Red
9	- Motor Diaphragm	Black
10	+ Motor Diaphragm	Purple

## Potentiometer Assignment

Designation	Part No.
LINOS MeVis-Cm 1.8 / 12 mm	266.0012.001.041
LINOS MeVis-Cm 1.6 / 16 mm	266.0016.001.041
LINOS MeVis-Cm 1.6 / 25 mm	266.0025.001.041
LINOS MeVis-Cm 1.6 / 35 mm	266.0035.001.041
LINOS MeVis-Cm 1.8 / 50 mm	266.0050.001.041

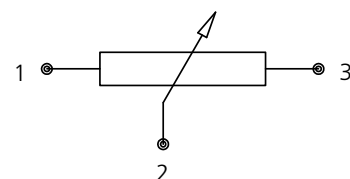

**Table 1: Specifications**

**Table: Wiring (customized adaptation possible)**

# Telecentric Lenses TL

- objective for 2D and 3D measurement purposes
- high resolution
- extreme low distortion (< 0.2 %)
- high transmission in the visible range
- insensitive to variation of working distance
- standard threads for combination with filters on front side
- compatible with LINOS rail systems like FLS and X 95
- rugged industrial design
- application:
  - vision technology
  - identification of parts
  - quality inspection
  - process control
  - automatisation



**Telecentric Lenses**

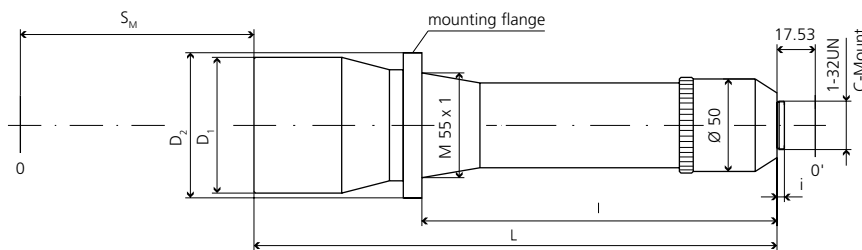

- $S_M$  Free working distance
- $D_1$  Max. lens diameter
- $D_2$  Front diameter
- $L$  Length of mounted lens
- $l$  Mounting flange distance
- $i$  Mounting thread length
- $o$  Object plane
- $o'$  Image plane

## Telecentric Lenses TL

Telecentric Objective Type	Camera Size	Object field - Ø	Part No.	N.A.	free working distance $s_M$	$D_1$	$D_2$	$L$	$l$
TL 1/2-15-120	1/2"	120 mm	265.0015.120.705	0.007	290 mm	138 mm	75 mm	397 mm	89 mm
TL 2/3-10-120	2/3"	120 mm	265.0010.120.745	0.01	290 mm	138 mm	75 mm	416 mm	114 mm
TL 1/2-6-60	1/2"	60 mm	265.0006.060.260	0.02	88 mm	70 mm	75 mm	216 mm	89 mm
TL 2/3-5-60	2/3"	60 mm	265.0005.060.270	0.02	92 mm	74 mm	75 mm	164 mm	89 mm
TL 1/2-3-55	1/2"	55 mm	265.0003.055.395	0.03	170 mm	70 mm	75 mm	208 mm	90 mm
TL 2/3-3-55	2/3"	55 mm	265.0002.028.280	0.03	170 mm	70 mm	75 mm	208 mm	90 mm
TL 1/2-2-28	1/2"	28 mm	265.0001.012.215	0.05	115 mm	60 mm	75 mm	147 mm	90 mm
TL 2/3-2-28	2/3"	28 mm	265.0001.012.215	0.05	115 mm	60 mm	75 mm	147 mm	90 mm
TL 1/2-1-12	1/2"	12 mm	265.0001.012.215	0.10	114 mm	40 mm	50 mm	87 mm	-
TL 2/3-1-12	2/3"	12 mm	265.0001.012.215	0.10	114 mm	40 mm	50 mm	87 mm	-

**Custom systems (e.g. other object size, working distance) on request.**

# Macro CCD Lenses

## Fixed and variable focal lengths for magnifications from 0.14 x to 8 x

Macro Lenses developed by Rodenstock Präzisionsoptik for CCD Cameras feature the highest resolution, excellent contrast, color neutrality and are virtually distortionfree.

### A large selection of Macro Lenses is available:

- a number of Macro Lenses with fixed focal lengths for magnifications of 0.14 x (ratio 1:7) to 8 x (ratio 8:1), which can be supplied with various fixed diaphragm aperture settings;
- a number of Macro Lenses with fixed focal lengths for magnifications of 2 x to 8 x, which are available in a choice of versions with parallel axis illumination for shadow-free illumination (for example in narrow recesses);

- a Macro Vario Lens covers the range from 0.8 x to 4 x continuously; front-mountable converters extend this range to 0.24 x.

The considerable working distance (see specifications on the following pages) simplify handling and lighting.



**Macro Lenses for CCD Cameras and magnification ratios from 1:7 to 8:1 (related to the image size on the CCD chip)**

## Macro Lenses for Magnification from 0.14 x to 1 x

- with fixed focal length for one specific magnification each
- versions with various fixed diaphragm aperture settings
- for 1/2" and 2/3" CCD Cameras
- C-mount threaded adapter
- the free working distance from the front edge of the lens is 90 mm

Depending on the application, it is possible to choose between the largest relative aperture or the greatest depth of field with low vignetting and thus with more consistent illumination of the image field.

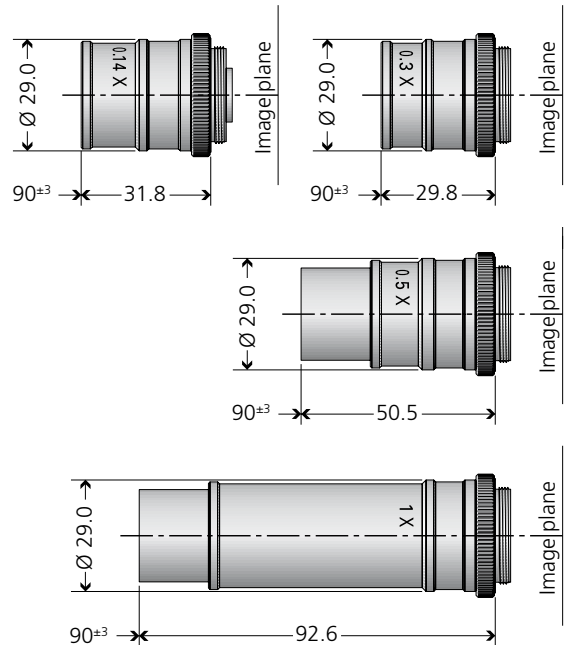

## Specifications

Lens designation	Macro CCD Lens 0.14 x	Macro CCD Lens 0.3 x	Macro CCD Lens 0.5 x	Macro CCD Lens 1 x
Lens focal length	15 mm	24 mm	35 mm	50 mm
Magnification on CCD	0.14 x (1:7.1)	0.3 x (1:3.3)	0.5 x (1:2)	1 x (1:1)
Magnification on 14" monitor with 1/2" CCD	approx. 6.3 x	approx. 13.5 x	approx. 22.5 x	approx. 45 x
Magnification on 14" monitor with 2/3" CCD	approx. 4.9 x	approx. 10.5 x	approx. 17.5 x	approx. 35 x
Object field with 1/2" CCD	46 x 34 mm <sup>2</sup>	21 x 16 mm <sup>2</sup>	13 x 10 mm <sup>2</sup>	6.4 x 4.8 mm <sup>2</sup>
Object field with 2/3" CCD	59 x 44 mm <sup>2</sup>	31 x 21 mm <sup>2</sup>	17 x 12 mm <sup>2</sup>	8.3 x 6.2 mm <sup>2</sup>
Available fixed diaphragm apertures (geometric value, in relation to 1: ∞)	4 5.6 8	3.5 5.6 8	- 5.6 8	4 5.6 8
Distortion	< 0.1 %	< 0.1 %	< 0.1 %	< 0.1 %
Rel. brightness in image corner with 2/3" CCD (related to 100% brightness in image center)	68 % (diaph. 4) 81 % (diaph. 5.6) 87 % (diaph. 8)	88 % (diaph. 3.5) 95 % (diaph. 5.6) 96 % (diaph. 8)	- 86 % (diaph. 5.6) 99 % (diaph. 8)	100 % (diaph. 4) 100 % (diaph. 5.6) 100 % (diaph. 8)
Resolution (related to object)	130 μm	60 μm	36 μm	18 μm
Object depth of field (related to 2/3" CCD and 350 TV lines)	±5 mm (diaph. 4) ±7 mm (diaph. 5.6) ±9 mm (diaph. 8)	±1.2 mm (diaph. 3.5) ±2 mm (diaph. 5.6) ±3 mm (diaph. 8)	- ±0.8 mm (diaph. 5.6) ±1.2 mm (diaph. 8)	±0.3 mm (diaph. 4) ±0.4 mm (diaph. 5.6) ±0.5 mm (diaph. 8)
Part No. for diaphragm 3.5	-	260.0030.001.020	-	-
Part No. for diaphragm 4	260.0014.001.020	-	-	260.0100.001.020
Part No. for diaphragm 5.6	260.0014.001.021	260.0030.001.021	260.0050.001.020	260.0100.001.021
Part No. for diaphragm 8	260.0014.001.022	260.0030.001.022	260.0050.001.021	260.0100.001.022

## Macro CCD Lenses for Magnifications of 2 x to 8 x

- with fixed focal length for one specific magnification each
- versions with and without vertical epi-illuminator
- for 1/2" and 2/3" CCD Cameras
- C-mount threaded adapters
- the free working distance from the front edge of the lens is 75 mm

The epi-illuminator focuses the light of a glass fiber light source into the observation beam path so that it is parallel to the optical axis, allowing completely shadow-free illumination even of narrow recesses.

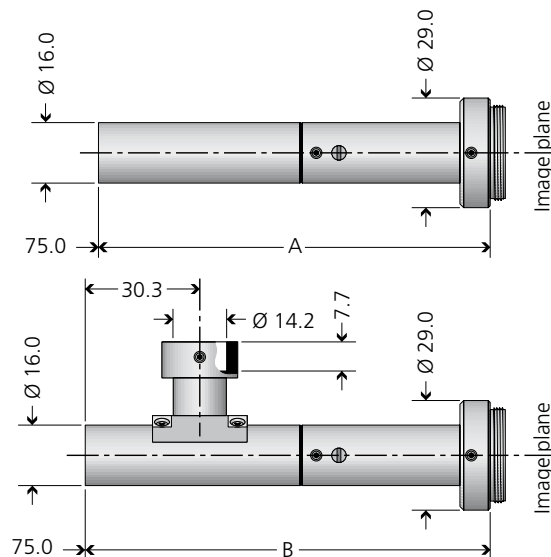

	A (w/o frontal illumination)	B (frontal illumin.)
Macro CCD Lens 2 x	72.8	76.2
Macro CCD Lens 4 x, 6 x, 8 x	103.6	107.1

## Specifications

Lens designation	Macro CCD Lens 2 x	Macro CCD Lens 4 x	Macro CCD Lens 6 x	Macro CCD Lens 8 x
Lens focal length	26 mm	20 mm	13 mm	9 mm
Magnification on the CCD	2 x (2:1)	4 x (4:1)	6 x (6:1)	8 x (8:1)
Magnification on 14" monitor with 1/2" CCD	approx. 90 x	approx. 180 x	approx. 270 x	approx. 360 x
Magnification on 14" monitor with 2/3" CCD	approx. 70 x	approx. 140 x	approx. 210 x	approx. 280 x
Object field with 1/2" CCD	3.2 x 2.4 mm <sup>2</sup>	1.6 x 1.2 mm <sup>2</sup>	1.1 x 0.8 mm <sup>2</sup>	0.8 x 0.6 mm <sup>2</sup>
Object field with 2/3" CCD	4.2 x 3.1 mm <sup>2</sup>	2.1 x 1.6 mm <sup>2</sup>	1.4 x 1.0 mm <sup>2</sup>	1.0 x 0.8 mm <sup>2</sup>
Object numerical aperture	0.076	0.076	0.076	0.076
Distortion	< 0.2 %	< 0.2 %	< 0.2 %	< 0.2 %
Relative brightness in the image corner for 2/3" CCD	100 %	100 %	100 %	100 %
Resolution (related to object)	24 μm	12 μm	9 μm	6 μm
Depth of field (with 2/3" CCD and 350 TV lines)	±0.2 mm	±0.1 mm	±0.07 mm	±0.06 mm
Part No. without epi-illuminator	261.0200.001.020	261.0400.001.020	261.0600.001.020	261.0800.001.020
Part No. with epi-illuminator	261.0200.002.020	261.0400.002.020	261.0600.002.020	261.0800.002.020

## Macro Vario Lenses for Magnifications from 0.8 x to 4 x

- variable focal length allows continuous adjustment to magnifications between 0.8 x and 4 x at a nearly constant working distance
- working distance 98 mm  $\pm$  4 mm
- for 1/2" and 2/3" CCD Cameras
- C-Mount threaded adapter
- the magnification range can be extended using one of four front-mountable converters:

Factor	Part No.
Converter 0.7 x	262.0840.070.020
Converter 0.5 x	262.0840.050.020
Converter 0.4 x	262.0840.040.020
Converter 0.3 x	262.0840.030.020

Continuous adjustment of the magnification provides considerable flexibility to accomplish the most diverse inspection tasks.

Moreover, this enables special details of the object under test to be found quickly at a low magnification first, then immediately magnified to a greater setting for accurate inspection.

As a result, they yield new magnifications 0.56 x ... 2.8 x; 0.4 x ... 2 x; 0.32 x ... 1.6 x and 0.24 x ... 1.2 x.

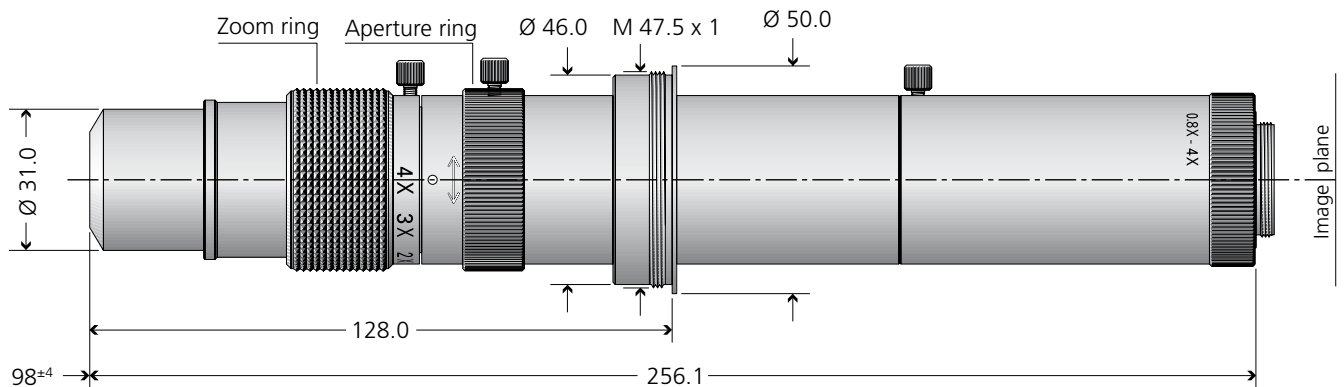

## Specifications

Lens designation Macro CCD Vario Lens 0.8x - 4x	Part No. 262.0840.001.020			
Lens focal length	84 mm	105 mm	110 mm	55 mm
Magnification on CCD	0.8 x (1:1.25)	1 x (1:1)	2 x (2:1)	4 x (4:1)
Magnification on 14" monitor with 1/2" CCD	approx. 36 x	approx. 45 x	approx. 90 x	approx. 180 x
Magnification on 14" monitor with 2/3" CCD	approx. 28 x	approx. 35 x	approx. 70 x	approx. 140 x
Object field with 1/2" CCD	8.0 x 6.0 mm <sup>2</sup>	6.4 x 4.8 mm <sup>2</sup>	3.2 x 2.4 mm <sup>2</sup>	1.6 x 1.2 mm <sup>2</sup>
Object field with 2/3" CCD	10.3 x 7.8 mm <sup>2</sup>	8.3 x 6.2 mm <sup>2</sup>	4.2 x 3.1 mm <sup>2</sup>	2.1 x 1.6 mm <sup>2</sup>
Largest diaphragm aperture	6.6	6	5.2	6
Distortion	< 0.1 %	< 0.1 %	< 0.1 %	< 0.1 %
Rel. brightness in the image corner (2/3" CCD)*	78 %	78 %	83 %	100 %
Resolution (related to object)*	40 μm	32 μm	16 μm	8 μm
Depth of field (with 2/3" CCD and 350 TV lines)	±0.5 mm	±0.4 mm	±0.2 mm	±0.1 mm

**\*all values are for an open diaphragm.**

# Measuring Lenses for Large Imaging Sensors

The measuring lenses developed by Rodenstock Präzisionsoptik feature the highest resolution, excellent contrast, minimum possible distortion and color neutrality. They sharply reproduce images all the way to the very corner edges.

- developed for the visible spectral range
- magnification extends from approx. 1:30 to over 1:1
- large image circle diameter; suitable for line cameras
- C-Mount adapter for CCD Cameras
- for many CCD applications, the focal length range from 25 to 105 mm is required, and magnifications between 1: ∞ and 1:2
- do not have any focusing possibility themselves; however, a focusing device is available as an accessory (please refer to page 27 "Modular Focus")
- lockable diaphragm aperture settings; no accidental changing possible



## Mechanical Dimensions of Measuring Lenses

### Lenses with a focal lengths of 25 to 35 mm

- mounting thread M 32.5 x 0.5
- adapter ring M 39 x 1/26" included

### Lenses with a focal lengths of 40 to 105 mm

- mounting thread M 39 x 1/26" (Leica mount)

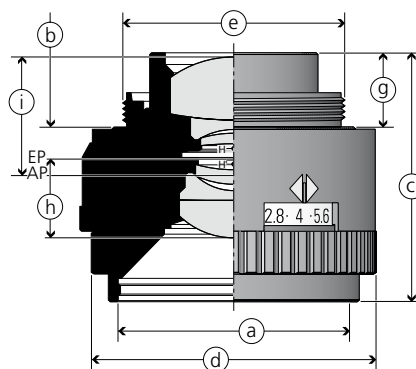

**Rodagon 1: 2.8 / 50 mm**  
6 lenses in 4 groups; diaphragm mount size 0

Please refer to the next page for specifications about the filter thread.

The dimensions "i" and "h" are not indicated in the chart.

Lens (Aperture ratio / Focal length)	Support dimensions for $\infty$	Lens length	Max. Lens $\emptyset$ without flange	Thread	Surface-focal plane distance to the rear
	b	c	d	e	g
Rogonar-S 1:4 / 25 mm	23.0 mm	28.0 mm	40.5 mm	M 32.5 x 0.5"	4.5 mm
Rogonar-S 1:4 / 35 mm	34.0 mm	28.0 mm	40.5 mm	M 32.5 x 0.5"	4.6 mm
Rogonar-S 1:2.8 / 50 mm	47.0 mm	37.5 mm	50.0 mm	M 39 x 1/26"	6.5 mm
Rogonar-S 1:4.5 / 60 mm	52.5 mm	36.5 mm	50.0 mm	M 39 x 1/26"	5.9 mm
Rogonar-S 1:4.5 / 75 mm	65.5 mm	36.5 mm	50.0 mm	M 39 x 1/26"	5.9 mm
Rogonar-S 1:4.5 / 90 mm	80.0 mm	36.5 mm	50.0 mm	M 39 x 1/26"	5.9 mm
Rogonar-S 1:4.5 / 105 mm	95.0 mm	36.5 mm	50.0 mm	M 39 x 1/26"	5.9 mm
Rodagon 1:4 / 28 mm	27.7 mm	30.0 mm	40.5 mm	M 32.5 x 0.5"	6.7 mm
Rodagon 1:4 / 35 mm	35.6 mm	32.5 mm	40.5 mm	M 39 x 1/26"	9.0 mm
Rodagon 1:2.8 / 50 mm	43.5 mm	43.5 mm	50.0 mm*	M 39 x 1/26"	13.0 mm
Rodagon 1:4 / 60 mm	56.0 mm	41.0 mm	50.0 mm*	M 39 x 1/26"	10.0 mm
Rodagon 1:4 / 80 mm	74.7 mm	44.5 mm	50.0 mm*	M 39 x 1/26"	13.5 mm
Rodagon 1:5.6 / 105 mm	99.5 mm	41.0 mm	50.0 mm*	M 39 x 1/26"	10.5 mm
Rodagon-WA 1:4 / 40 mm	36.5 mm	37.2 mm	50.0 mm*	M 39 x 1/26"	6.5 mm
Rodagon-WA 1:4 / 60 mm	55.5 mm	41.0 mm	50.0 mm*	M 39 x 1/26"	10.0 mm
Rodagon-WA 1:4 / 80 mm	77.0 mm	44.0 mm	50.0 mm*	M 39 x 1/26"	13.0 mm
Apo-Rodagon-N 1:2.8 / 50 mm	46.0 mm	46.5 mm	50.0 mm*	M 39 x 1/26"	15.7 mm
Apo-Rodagon-N 1:4 / 80 mm	77.0 mm	43.0 mm	50.0 mm*	M 39 x 1/26"	12.2 mm
Apo-Rodagon-N 1:5.6 / 105 mm	99.1 mm	54.3 mm	50.0 mm*	M 39 x 1/26"	18.0 mm
Apo-Rodagon-D 1:4 / 75 mm	136.7 mm at M = 1 x	53.0 mm	50.0 mm*	M 39 x 1/26"	18.7 mm
Apo-Rodagon-D 2 x 1:4.5 / 75 mm	109.4 mm at M = 2 x	43.0 mm	50.0 mm*	M 39 x 1/26"	12.5 mm
Apo-Rodagon-D 1:5.6 / 120 mm	232,8 mm at M = 1 x	43.0 mm	50.0 mm*	M 39 x 1/26"	12.7 mm

**\*Lever for switching between half-stage locking and continuous diaphragm aperture settings protrudes 2 mm above the mount of the 50-mm  $\emptyset$ .**

## Various Lens Types for Different Requirements

- **Rogonar-S**  
Inexpensive lens with good imaging performance.  
Optimal price/performance ratio.
- **Rodagon**  
High-performance lens featuring a highly consistent imaging quality and broad magnification range.
- **Rodagon-WA**  
High-performance lens with extended viewing angle (shorter focal length for the same image field possible).
- **Apo-Rodagon-N**  
Apochromatically corrected lens designed to meet the highest requirements in an especially broad magnification range.
- **Apo-Rodagon-D**  
Apochromatically corrected special lens designed to meet the highest requirements for magnifications from 1:5 to 1:3.

## CCD chip size or CCD line array length and image circle diameter

For CCD area chips, the image height, and for CCD line arrays, their active length may not be greater than the image circle diameter of the lens used. If necessary, please check the image circle diameter in the table provided.

Focusing option available through the use of "Modular Focus". Extension tubes for setting specific magnification ranges can be supplied.



**Modular Focus with the measuring lens used**

see p. 27 for "Modular Focus".

The following table shows which magnifications can be obtained using "Modular Focus" and one or several extension tubes along with the individual measuring lenses.

**Obtainable magnification ranges  
(related to C-mount camera thread)**

Specifications		Image circle Ø at 1: ∞ and fully open diaphragm	Filter thread a	Part No.
Tube length (lens up to C-Mount) Support dimension (lens up to CCD)				
<b>Lens (Aperture ratio / Focal length)</b>				
Rogonar-S	1:4 / 25 mm	18 mm	M 30.5 x 0.5	208.0025.001.000
Rogonar-S	1:4 / 35 mm	25 mm	M 30.5 x 0.5	208.0035.001.000
Rogonar-S	1:2.8 / 50 mm	35 mm	M 40.5 x 0.5	208.0050.001.000
Rogonar-S	1:4.5 / 60 mm	45 mm	M 40.5 x 0.5	208.0060.001.000
Rogonar-S	1:4.5 / 75 mm	55 mm	M 40.5 x 0.5	208.0075.001.000
Rogonar-S	1:4.5 / 90 mm	65 mm	M 40.5 x 0.5	208.0090.001.000
Rogonar-S	1:4.5 / 105 mm	75 mm	M 40.5 x 0.5	208.0105.001.000
Rodagon	1:4 / 28 mm	25 mm	M 30.5 x 0.5	270.0028.001.040
Rodagon	1:4 / 35 mm	30 mm	M 40.5 x 0.5	270.0035.001.000
Rodagon	1:2.8 / 50 mm	40 mm	M 40.5 x 0.5	270.0051.001.040
Rodagon	1:4 / 60 mm	50 mm	M 40.5 x 0.5	270.0060.001.040
Rodagon	1:4 / 80 mm	65 mm	M 40.5 x 0.5	270.0081.001.040
Rodagon	1:5.6 / 105 mm	80 mm	M 40.5 x 0.5	270.0105.001.040
Rodagon-WA	1:4 / 40 mm	35 mm	M 40.5 x 0.5	277.0040.001.040
Rodagon-WA	1:4 / 60 mm	55 mm	M 40.5 x 0.5	277.0060.001.040
Rodagon-WA	1:4 / 80 mm	75 mm	M 40.5 x 0.5	277.0080.001.040
Apo-Rodagon-N	1:2.8 / 50 mm	40 mm	M 40.5 x 0.5	275.0050.001.040
Apo-Rodagon-N	1:4 / 80 mm	70 mm	M 40.5 x 0.5	275.0080.001.040
Apo-Rodagon-N	1:5.6 / 105 mm	80 mm	M 40.5 x 0.5	275.0105.001.040
Apo-Rodagon-D	1:4 / 75 mm	80 mm (at 1:1)*	M 40.5 x 0.5	273.0075.001.040
Apo-Rodagon-D 2 x	1:4.5 / 75 mm	80 mm (at 1:2)*	M 40.5 x 0.5	273.0075.002.040
Apo-Rodagon-D	1:5.6 / 120 mm	80 mm (at 1:2)*	M 40.5 x 0.5	273.0120.001.040

\* optimized for this imaging ratio.

Modular Focus without extension tube	Modular Focus with 1 Tube	Modular Focus with 2 Tubes	Modular Focus with 3 Tubes
20.3 ... 45.3 mm 37.8 ... 62.8 mm	44.8 ... 69.8 mm 62.3 ... 87.3 mm	69.3 ... 94.3 mm 86.8 ... 111.8 mm	93.8 ... 118.8 mm 111.3 ... 136.3 mm
1:5.5 ... 1:2.1			
1: ∞ ... 1:2.0			
1: ∞ ... 1:3.2	1:3.2 ... 1:1.3		
1: ∞ ... 1:5.8	1:5.8 ... 1:1.7		
	1: ∞ ... 1:3.4	1:3.4 ... 1:1.6	
	1: ∞ ... 1:12.3	1:12.3 ... 1:2.8	1:2.8 ... 1:1.6
		1: ∞ ... 1:6.3	1:6.3 ... 1:2.5
1: ∞ ... 1:1.1			
1: ∞ ... 1:2.1			
1: ∞ ... 1:2.6	1:2.6 ... 1:1.1		
1: ∞ ... 1:9.1	1:9.1 ... 1:2.0	1:2.0 ... 1:1.1	
	1: ∞ ... 1:6.4	1:6.4 ... 1:2.2	1:2.2 ... 1:1.3
		1: ∞ ... 1:8.7	1:8.7 ... 1:2.9
1:31 ... 1:1.5			
1: ∞ ... 1:8.4	1:8.4 ... 1:1.9		
	1: ∞ ... 1:8.0	1:8.0 ... 1:2.4	1:2.4 ... 1:1.4
1: ∞ ... 1:3.0	1:3.0 ... 1:1.2		
	1: ∞ ... 1:8.0	1:8.0 ... 1:2.4	1:2.4 ... 1:1.4
		1: ∞ ... 1:8.2	1:8.2 ... 1:2.8
Modular Focus with a special tube of a length of 87.4 mm:			1:2.1 ... 1:1.2
Modular Focus with a special tube of a length of 60.0 mm:			1:2.9 ... 1:1.5
On request			

# Mechanical Accessories

## Mechanical Adaptions

Since the LINOS "Measuring Lenses for Large Foramt Sensors" have a quite unusual thread (M 39 x 1/26") and no focusing device we have created a complete range of ways to adapt those lenses to all existing camera systems:

### Modular Focus

A helical mount with modular possibilities of adapting numerous LINOS CCD Lenses onto different camera threads.

Using "Lens adapters" for M 32,5 and M 39 lens threads and "Camera adapters" for all existing camera threads like C-mount, F-mount, M 42 x 1 and individual camera threads for DALSA, ATMEL, BASLER etc.

The Modular Focus is designed to keep the lens from rotating during focusing.

### Smart Focus

Low cost version of Modular Focus with M 39 thread for lenses and using the camera adapters from the Modular Focus system.

Difference to Modular Focus? The lift is shorter than the one from Modular Focus and the lens is rotating while it is focused.

### Focus Adapter System

The lens adapter 1094.2408.005.101 is used to enlarge the serial M 39 thread up to M 42 x 1.

Together with retaining ring 1094.2408.005.102, which fixes the reached focus position, it is already possible to mount the lenses onto M 42 camera threads. Referring to focal length and magnification it will be necessary to use extension tubes like 1094.2408.005.103.

The Focus Adapter System was created as a reasonable alternative to the existing helical mounts. It is mainly used in OEM applications where a quick and safe adaption of the well known LINOS lenses is needed.

# Modular Focus

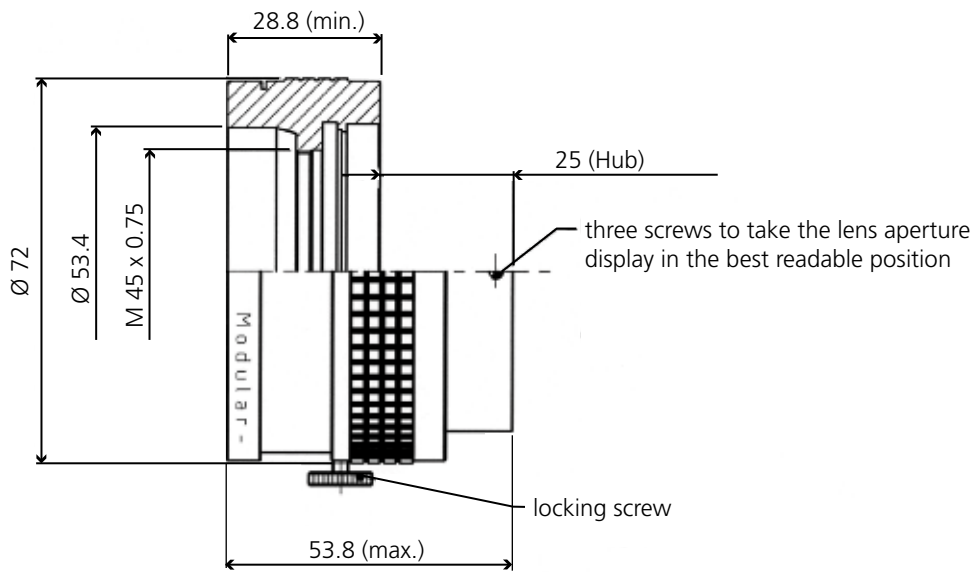

example of application

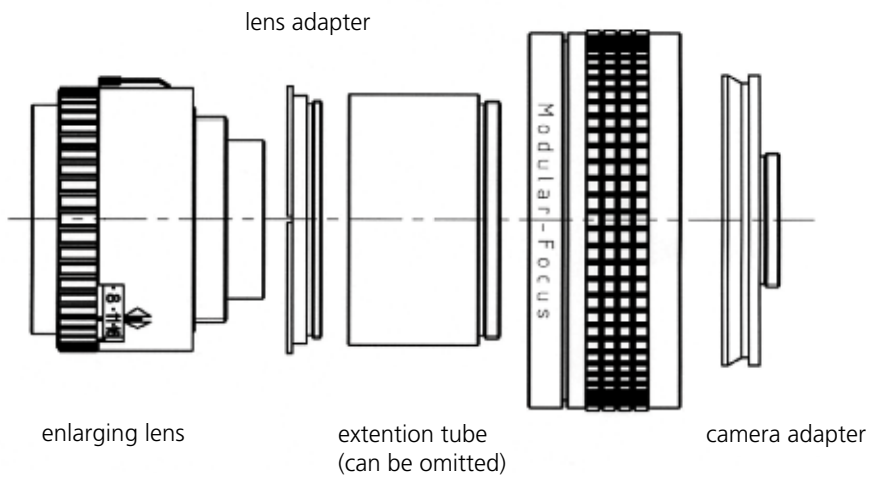

# Smart Focus

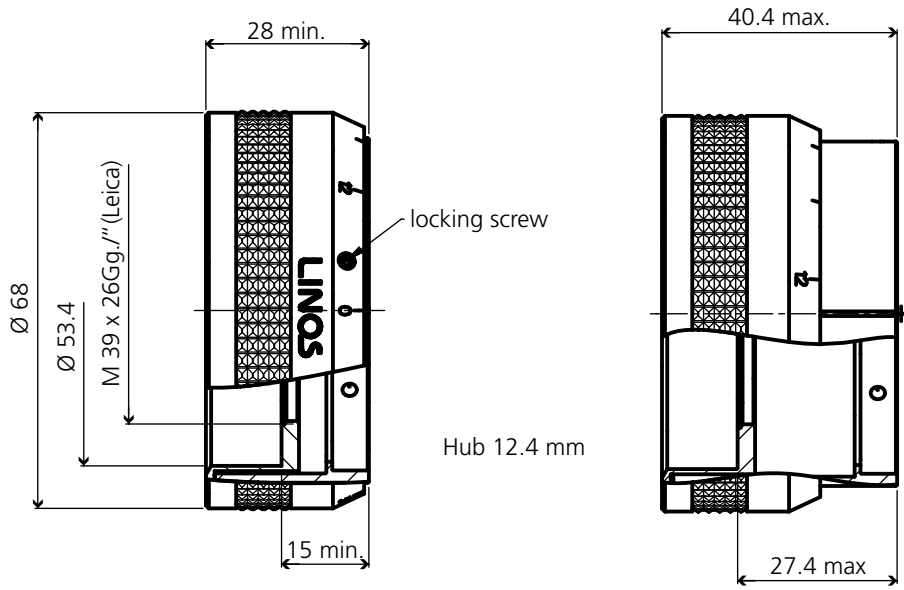

## example of application

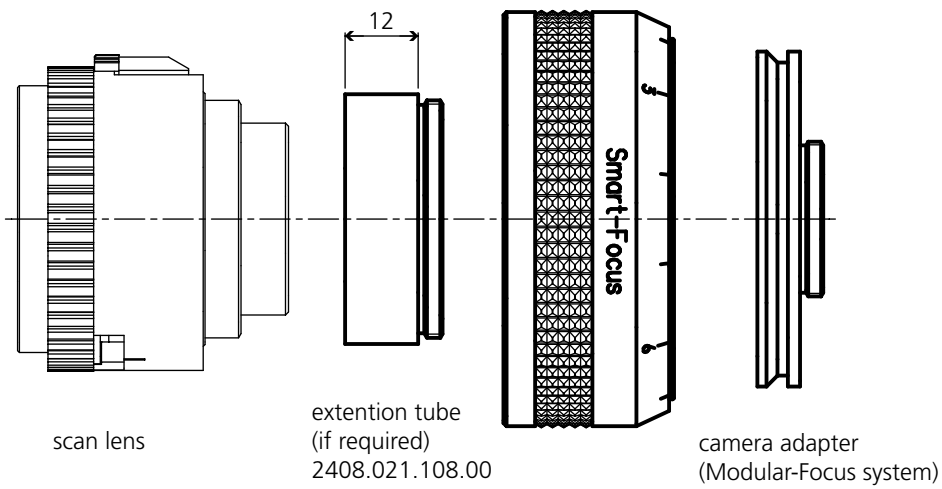

# Focus Adapter System

examples of application

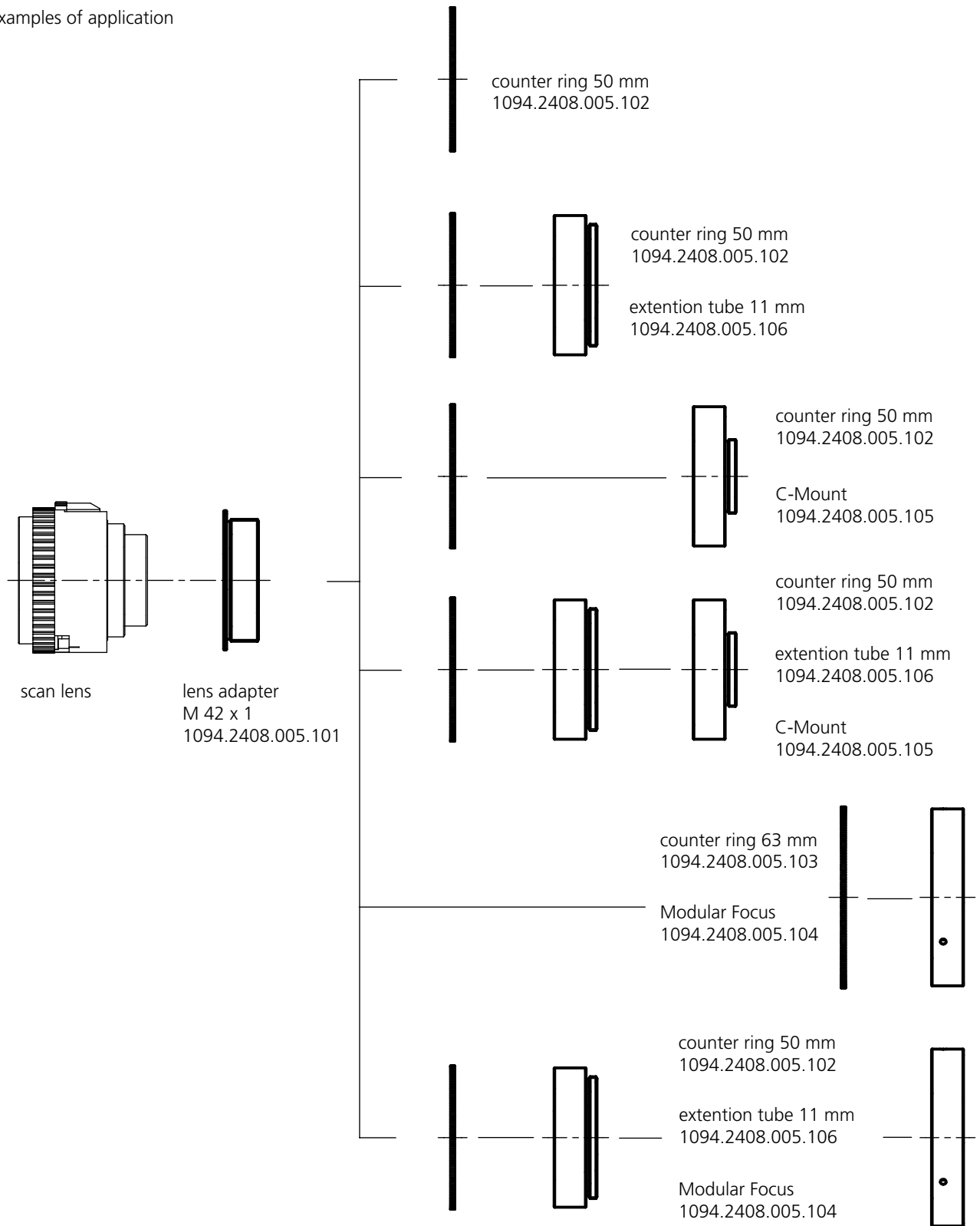

# Fax Form

**LINOS Photonics GmbH & Co. KG**

Isartalstrasse 43  
D-80469 Munich  
Germany

**Fax +49 (0)89 72 02-141**

Phone +49 (0)89 72 02-465  
E-mail georg.zeitelhack@linos.de  
Internet www.linos.de

Surname \_\_\_\_\_

Phone \_\_\_\_\_

First Name \_\_\_\_\_

Fax \_\_\_\_\_

Titel \_\_\_\_\_

E-mail \_\_\_\_\_

Company \_\_\_\_\_

Date \_\_\_\_\_

Department \_\_\_\_\_

Signature \_\_\_\_\_

Address \_\_\_\_\_

Zip \_\_\_\_\_ City \_\_\_\_\_

Country \_\_\_\_\_

- I ask for a call
- I ask for a quotation
- I need further information on

\_\_\_\_\_  
\_\_\_\_\_  
\_\_\_\_\_  
\_\_\_\_\_

Please send me:

- LINOS Catalog, english
- LINOS Company Brochure, english

Other:

\_\_\_\_\_  
\_\_\_\_\_  
\_\_\_\_\_  
\_\_\_\_\_

# Specification Sheet Optical Systems

System designation \_\_\_\_\_

Customer name \_\_\_\_\_

Contact person \_\_\_\_\_

Date \_\_\_\_\_

Focal length	_____ mm	Magnification	_____
Focal ratio	_____ mm	Object-first-surface distance	_____ mm
Diameter of first surface	_____ mm	Image-final-surface distance	_____ mm
Diameter of final surface	_____ mm	Image-first-surface distance	_____ mm
Diameter of entrance pupil	_____ mm	Object-image distance	_____ mm
Diameter of exit pupil	_____ mm	Pupil magnification	_____
Object height (half-height)	_____ mm	Entrance pupil first-surface distance	_____ mm
Image height (half-height)	_____ mm	Exit pupil final-surface distance	_____ mm
Object subtended half-angle	_____ °	Wavelength (range)	_____ nm
Image subtended half-angle	_____ °	Wavelength weightings	_____

Special requirements/conditions (mechanical requirements, ambient conditions, etc.)

---



---



---



---

Performance requirements (spot diameter, MTF, distortion, vignetting, concentricity, transmittance, etc.)

---



---



---



---

Additional remarks (intended application, objects, light sources, detectors involved, etc.)

---



---



---



---

Quantities required \_\_\_\_\_

Desired shipment schedule \_\_\_\_\_

Units \_\_\_\_\_ ea. \_\_\_\_\_

**Specifications subject to change without notice. We shall not be liable for any errors, including printing errors. This catalog may be reprinted only with our express permission.**

**www.linos.com**

LINOS Photonics GmbH & Co. KG  
Isartalstrasse 43  
D-80469 Munich  
Germany

Phone +49 (0)89 72 02-465  
Fax +49 (0)89 72 02-141  
E-mail [georg.zeitelhack@linos.de](mailto:georg.zeitelhack@linos.de)

LINOS Photonics Inc.  
459 Fortune Boulevard  
Milford, MA 01757-1745  
USA

Phone +1 (508) 478-6200  
Fax +1 (508) 478-5980  
E-mail [info@linos.com](mailto:info@linos.com)

LINOS Photonics Ltd.  
2 Drakes Mews, Crownhill  
Milton Keynes, Bucks MK8 OER  
UK

Phone +44 (0) 1908 262525  
Fax +44 (0) 1908 262526  
E-mail [sales@linos.co.uk](mailto:sales@linos.co.uk)

LINOS Photonics SARL  
90, Avenue de Lanessan  
69410 Champagne au Mont d'Or  
France

Phone +33 (0)4 72 52 04 20  
Fax +33 (0)4 72 53 92 96  
E-mail [info-fr@linos.com](mailto:info-fr@linos.com)

