

Flea®

Miniature IEEE-1394 Camera



POINT GREY
RESEARCH

- 1/3" Sony® CCD sensor
- Compact size, 30x31x29mm
- High speed, 640x480 at 60FPS
- External trigger, strobe output
- 12-bit analog to digital converter
- Image acquisition software included

The Flea® is Point Grey's most compact IEEE-1394a camera designed to fit spaces as small as 30x31mm. The 640x480 model of the Flea runs at 60FPS and the 1024x768 model runs at 30FPS. Equipped with a 1/3" Sony® CCD sensor and a 12-bit analog to digital converter, the camera delivers high quality images ideal for demanding imaging applications such as high speed assembly inspection and robot control tasks.

Triggering and GPIO

The Flea camera has four General Purpose IO pins (GPIO) that can be configured as external trigger, strobe output or digital input/output. The camera also has a serial port built-in to the GPIO connector and through the IEEE-1394 interface allows for control of devices local to the camera.

Binning and ROI

Binning and region of interest (ROI) features are available on the camera for increased frame rate and sensitivity. For example, users can define a 320x240 region of interest on the 640x480 Flea camera to achieve 99FPS.

Multi-Camera Networking

The IEEE-1394 protocol allows multiple cameras to broadcast images simultaneously with guaranteed image delivery. If multiple Flea cameras are on the same bus, they will automatically synchronize their image acquisition times. IEEE-1394 allows broadcasting of parameters to multiple cameras at the same time.

Software

The FlyCapture® software development kit (SDK) is included with all Point Grey Research® Imaging Products. The SDK is designed to allow image acquisition, camera control and comes with a variety of C/C++ source code examples. In addition, the camera's firmware is upgradable in field via the IEEE-1394 interface.

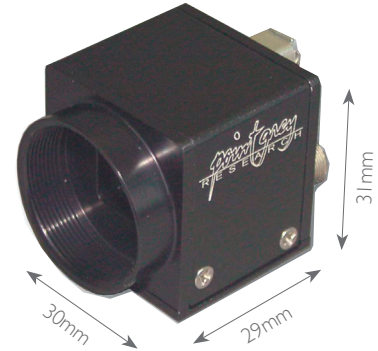

Flea® camera

Development Kit Includes:

- 4.5 meter, 6-pin, IEEE-1394 cable with 2 ferrites
- IEEE-1394 OHCI PCI Host Adapter 400Mbps card
- Tripod mounting adapter
- Hirose HR25 male GPIO connector pre-wired for easy triggering
- FlyCapture® SDK CD (C/C++ API and device drivers)

Recommended System Configuration:

- Intel® Pentium 4 2.0GHZ or compatible processor
- 512MB of RAM
- Windows® 2000 or XP Service Pack 1
- Microsoft® Visual C++ 6.0 for software development
- 32-bit standard PCI slot for the IEEE-1394 PCI card

Flea® Specifications

Specification	640x480	1024x768
Overview	Boxed IEEE-1394 camera	
Imaging Sensor	Sony® ICX424AQ/AL 1/3" CCD sensor Progressive scan, global shutter	Sony® ICX204AQ/AL 1/3" CCD sensor Progressive scan, global shutter
Resolution	640x480 BW or Color	1024x768 BW or Color
Format	8-bit or 16-bit, 12-bit AtoD	
Pixel Size	7.4µm x 7.4µm	4.65µm x 4.65µm
Frame Rates	640x480 at 60FPS	1024x768 at 30FPS
Partial Image Modes	Format 7_Mode_0 (ROI), Format 7_Mode_1 and _2 pixel binning	
Voltage Requirements	8-32V	
Power Consumption	< 3W	
Gain	Automatic / Manual modes at 0.035dB -5.45 to 30.75dB	Automatic / Manual modes at 0.035dB -6.8 to 29.4dB
Shutter	Automatic / Manual modes 0.04ms to 66.66 ms at 15FPS	Automatic / Manual modes 0.03ms to 66.6 ms at 15FPS
Trigger Modes	DCAM v.1.31 Trigger_Mode (0,1,3)	
Signal To Noise Ratio	> 59dB	
Dimensions	30x31x29mm w/o optics	
Mass	60g without optics	
Camera Specification	IIDC 1394-based Digital Camera Specification v1.31	
Emissions Compliance	Complies with CE rules and Part 15 Class B of FCC Rules	
Operating Temperature	Commercial grade electronics rated from 0° to 45°C	
Storage Temperature	-30° to 60°C	

Flea® Camera Dimensional Drawings

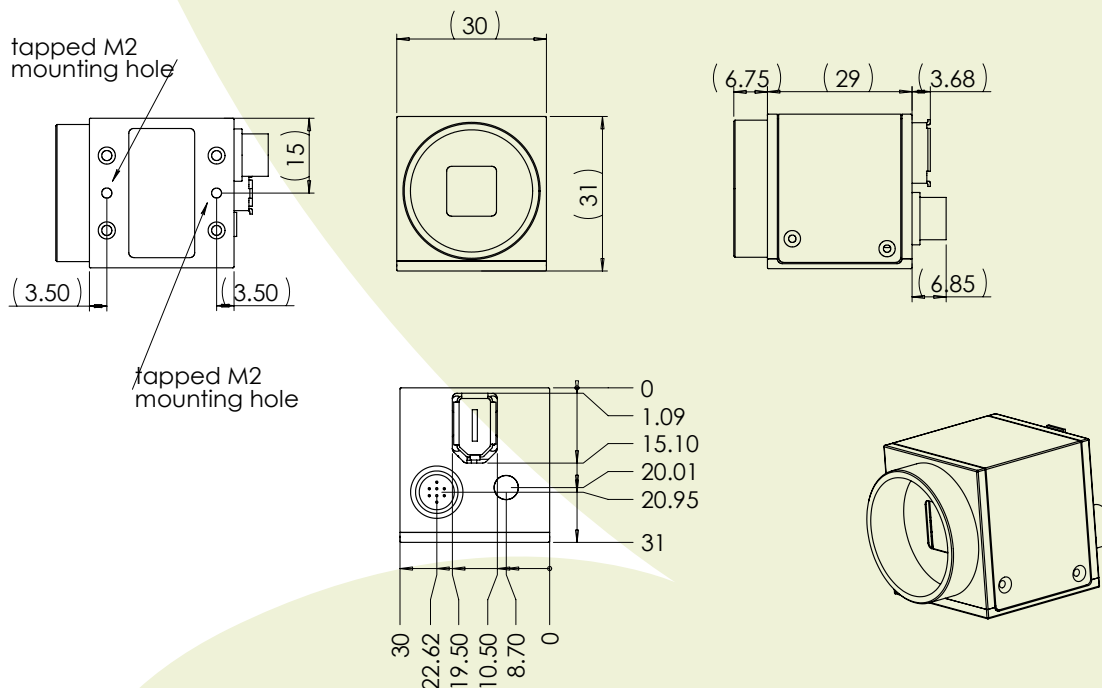

Measurements in mm. CAD drawings available online at www.ptgrey.com/support

November 2006