

# Scorpion®

## High Resolution + High Sensitivity



POINT GREY  
RESEARCH

- 0.3M, 1.4M or 2.0M pixels
- 1/2" or 1/1.8" Sony® CCD's
- IEEE-1394a 400Mb/s digital interface
- External trigger and strobe
- Automatic inter-camera synchronization

The Scorpion IEEE-1394 camera platform is available with a variety of CCD image sensors designed for demanding imaging applications.

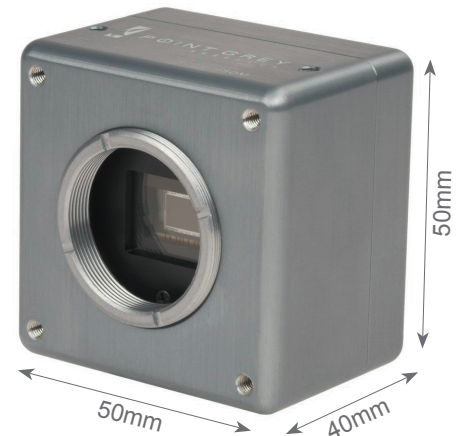

Scorpion IEEE-1394 digital camera

Models	
SCOR-20SO	Sony 1/1.8" CCD, BW or Color, 1628x1236 at 15 FPS
SCOR-14SO	Sony 1/2" CCD, BW or Color, 1392x1040 at 19 FPS
SCOR-03SO	Sony® 1/2" CCD, BW, 658x494 at 60 FPS

### Triggering and GPIO

The Scorpion camera has a 12-pin connector on the back of the case. The GPIO is a programmable interface that allows the user to coordinate the camera with external devices such as light sources and GPS units. It can be programmed to accept external trigger signals that initiate the start of exposure, output variable strobe patterns, or send and receive RS232 serial data. The GPIO pins are TTL 3.3V pins.

### Region of Interest (ROI) & Pixel Binning

The Scorpion camera supports Format\_7 custom image modes such as pixel binning and region of interest (ROI) to achieve faster frame rates and higher sensitivity.

### Automatic Synchronization

Multiple Scorpion cameras networked on the same IEEE-1394 bus are automatically synchronized to within 125µs (maximum deviation) of each other, and can synchronize across buses using Point Grey MultiSync™ software.

### Software

The FlyCapture® software development kit (SDK) is included with all Point Grey Research imaging products. The SDK includes a camera device driver, full software library with Application Programming Interface (API), example programs, and source code for a quick start in the C/C++ programming environment.

### Exposure and Gain Controls

The Scorpion features both manual and auto controls of shutter and gain settings for each image.

### Additional Features

Additional features of the Scorpion include: a 10-bit linear ADC; gamma and programmable LUT; timestamp info embedded in the image; and firmware that can be updated in-field via the IEEE-1394 interface.

### Development Kit Includes:

- 4.5 meter, 6-pin to 6-pin, IEEE-1394a cable
- IEEE-1394 OHCI PCI Host Adapter 400Mbps card
- Tripod mounting adapter
- Hirose HR10 male GPIO connector prewired for easy triggering
- FlyCapture SDK CD(C/C++ API and device drivers)

### Recommended System Configuration:

- Intel® Pentium 4 2.0GHZ or compatible processor
- 512MB of RAM
- Windows® 2000 or XP Service Pack 1
- Microsoft® Visual C++ 6.0 for software development
- 32-bit standard PCI slot for the IEEE-1394 PCI card

# Scorpion® Specifications

Specification	SCOR-03SO	SCOR-14SO	SCOR-20SO
Imaging Sensor Type	Sony progressive scan interline transfer CCD's with square pixels and global shutter		
Sensor Model	Sony ICX414 1/2" CCD	Sony ICX267 sensor 1/2" CCD	Sony ICX274 1/1.8" CCD
Maximum Resolution	658x494 BW	1392x1040 BW or Color	1628x1236 BW or Color
Pixel Size	9.9µm x 9.9µm	4.65µm x 4.65µm	4.4µm x 4.4µm
Analog-to-Digital Converter	Analog Devices 12-bit ADC		
Video Data Output	8-bit or 16-bit digital data		
Digital Interface	6-pin IEEE-1394a for camera control, video data transmission, and power		
Maximum Frame Rate	<b>658x494 at 60 FPS</b>	<b>1392x1040 at 19 FPS</b>	1600x1200 at 15 FPS
Partial Image Modes	pixel binning and region of interest modes via Format_7		
General Purpose I/O	12-pin Hirose HR10 general purpose input/output connector 4 pins for external trigger or strobe / 4 pins RS232 serial port / 2 pin +3.3V		
Voltage Requirements	8-32V		
Power Consumption (max at 12V)	2.6W	3.5W	3.5W
Gain	0 to 31dB	0 to 25dB	0 to 25dB
Shutter	80µs to 16ms at 60FPS	20µs to 66 ms at 19FPS	110µs to 70ms at 14FPS
Synchronization	via external trigger, software trigger, or free-running		
Trigger Modes	DCAM v1.31 Trigger Modes 0, 1, 3 and 14		
Signal To Noise Ratio (min at 0dB)	61dB	61db	57dB
Dimensions	50x50x40mm without optics		
Mass	125g without optics		
Camera Specification	IIDC 1394-based Digital Camera Specification v1.31		
Lens Mount	C/CS-mount (5mm C-mount adapter included)		
Emissions Compliance	Complies with CE rules and Part 15 Class A of FCC Rules		
Operating Temperature	Commercial grade electronics rated from 0° to 45°C		
Storage Temperature	-30° to 60°C		

## Scorpion® Dimensional Drawings

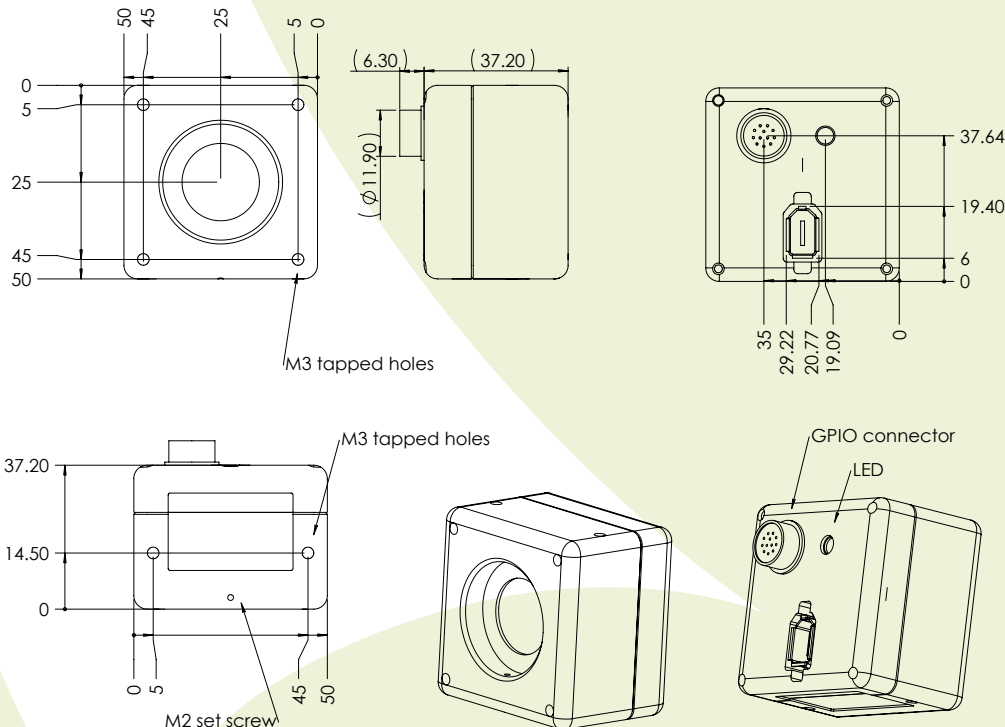

Measurements in mm. CAD drawings available online at [www.ptgrey.com/support](http://www.ptgrey.com/support)

Sep 07